

AL5DF-PS

7-16 DIN Female Positive Stop™ for 7/8 in AL5-50 and AVA5-50 cable replaced by AL5DF-PSA

OBSOLETE



CHARACTERISTICS

General Specifications

Interface	7-16 DIN Female
Body Style	Straight
Brand	HELIAX® Positive Stop™
Mounting Angle	Straight

Electrical Specifications

Connector Impedance	50 ohm
Operating Frequency Band	0 – 5200 MHz
Cable Impedance	50 ohm
3rd Order IMD, typical	-120 dBm @ 910 MHz
3rd Order IMD Test Method	Two +43 dBm carriers
RF Operating Voltage, maximum (vrms)	1415.00 V
dc Test Voltage	4000 V
Outer Contact Resistance, maximum	1.50 mOhm
Inner Contact Resistance, maximum	0.40 mOhm
Insulation Resistance, minimum	5000 MOhm
Average Power	3.0 kW @ 900 MHz
Peak Power, maximum	40.00 kW
Insertion Loss, typical	0.05 dB
Shielding Effectiveness	-130 dB

Outline Drawing

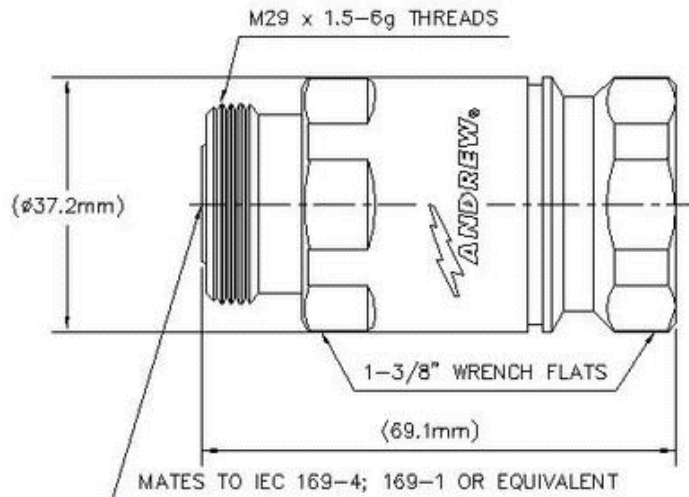

Mechanical Specifications

Outer Contact Attachment Method	Ring-flare
Inner Contact Attachment Method	Captivated
Outer Contact Plating	Trimetal
Inner Contact Plating	Silver
Attachment Durability	25 cycles
Interface Durability	50 cycles
Interface Durability Method	IEC 61169-4:9.5
Connector Retention Tensile Force	1334 N 300 lbf
Connector Retention Torque	8.13 N-m 72.00 in lb
Insertion Force	200.17 N 45.00 lbf
Insertion Force Method	IEC 61169-1:15.2.4
Pressurizable	No

Dimensions

Nominal Size	7/8 in
Diameter	37.21 mm 1.47 in
Length	69.09 mm 2.72 in
Weight	220.00 g 0.49 lb

Environmental Specifications

Operating Temperature	-55 °C to +85 °C (-67 °F to +185 °F)
Storage Temperature	-55 °C to +85 °C (-67 °F to +185 °F)
Immersion Depth	1 m
Immersion Test Mating	Unmated

Product Specifications

AL5DF-PS

Immersion Test Method	IEC 60529:2001, IP68
Water Jetting Test Mating	Unmated
Water Jetting Test Method	IEC 60529:2001, IP66
Moisture Resistance Test Method	MIL-STD-202F, Method 106F
Mechanical Shock Test Method	MIL-STD-202F, Method 213B, Test Condition C
Thermal Shock Test Method	MIL-STD-202F, Method 107G, Test Condition A-1, Low Temperature -55 °C
Vibration Test Method	IEC 60068-2-6
Corrosion Test Method	MIL-STD-1344A, Method 1001.1, Test Condition A

Standard Conditions

Attenuation, Ambient Temperature	20 °C		68 °F
Average Power, Ambient Temperature	40 °C		104 °F

Return Loss/VSWR

Frequency Band	VSWR	Return Loss (dB)
824–1019 MHz	1.02	39.00
1710–1044 MHz	1.02	39.00
1850–1990 MHz	1.02	38.80
1910–2200 MHz	1.03	37.50
2200–2700 MHz	1.03	35.60
3010–4000 MHz	1.13	24.60
4010–5200 MHz	1.21	20.60

Regulatory Compliance/Certifications

Agency	Classification
RoHS 2002/95/EC	Compliant by Exemption
China RoHS SJ/T 11364-2006	Above Maximum Concentration Value (MCV)



* Footnotes

Immersion Depth	Immersion at specified depth for 24 hours
Insertion Loss, typical	$0.05\sqrt{\text{freq (GHz)}}$ (not applicable for elliptical waveguide)