

78EZDF

7-16 DIN Female EZfit® for 7/8 in FXL-780 and AVA5-50 cable



CHARACTERISTICS

General Specifications

Interface	7-16 DIN Female
Body Style	Straight
Brand	EZfit®
Mounting Angle	Straight

Electrical Specifications

Connector Impedance	50 ohm
Operating Frequency Band	0 – 5000 MHz
Cable Impedance	50 ohm
3rd Order IMD, typical	-116 dBm @ 1800 MHz
3rd Order IMD Test Method	Two +43 dBm carriers
RF Operating Voltage, maximum (vrms)	1415.00 V
dc Test Voltage	4000 V
Outer Contact Resistance, maximum	1.50 mOhm
Inner Contact Resistance, maximum	0.40 mOhm
Insulation Resistance, minimum	5000 MOhm
Peak Power, maximum	40.00 kW
Insertion Loss, typical	0.05 dB

Outline Drawing

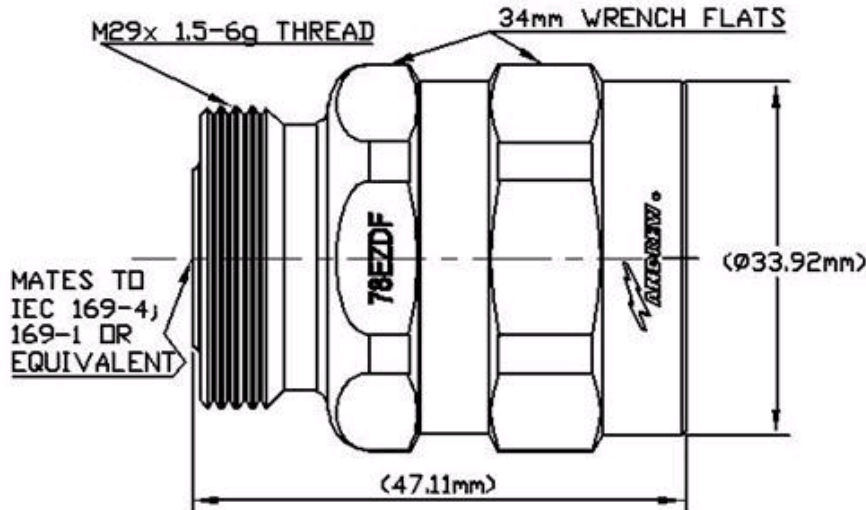

Mechanical Specifications

Outer Contact Attachment Method	Clamp
Inner Contact Attachment Method	Captivated
Outer Contact Plating	Trimetal
Inner Contact Plating	Silver
Attachment Durability	25 cycles
Interface Durability	50 cycles
Interface Durability Method	IEC 61169-4:9.5
Connector Retention Tensile Force	1334 N 300 lbf
Connector Retention Torque	8.13 N-m 72.00 in lb
Insertion Force	200.17 N 45.00 lbf
Insertion Force Method	IEC 61169-1:15.2.4
Pressurizable	No

Dimensions

Nominal Size	7/8 in
Diameter	37.10 mm 1.46 in
Length	47.90 mm 1.89 in
Weight	136.60 g 0.30 lb

Environmental Specifications

Operating Temperature	-40 °C to +85 °C (-40 °F to +185 °F)
Storage Temperature	-55 °C to +85 °C (-67 °F to +185 °F)
Immersion Depth	1 m
Immersion Test Mating	Mated

Product Specifications

78EZDF

Immersion Test Method	IEC 60529:2001, IP68
Water Jetting Test Mating	Mated
Water Jetting Test Method	IEC 60529:2001, IP66
Moisture Resistance Test Method	IEC 60529, IP68
Mechanical Shock Test Method	IEC 60068-2-27
Vibration Test Method	IEC 60068-2-6
Corrosion Test Method	IEC 60068-2-11, Test Condition Ka

Standard Conditions

Attenuation, Ambient Temperature	20 °C 68 °F
Average Power, Ambient Temperature	40 °C 104 °F

Return Loss/VSWR

Frequency Band	VSWR	Return Loss (dB)
50–1000 MHz	1.02	40.00
1000–1900 MHz	1.03	38.00
1900–2200 MHz	1.04	34.00
2200–2700 MHz	1.06	31.00
2700–3600 MHz	1.07	30.00
3600–5000 MHz	1.09	27.00

Regulatory Compliance/Certifications

Agency	Classification
RoHS 2002/95/EC	Compliant by Exemption
China RoHS SJ/T 11364-2006	Above Maximum Concentration Value (MCV)
ISO 9001:2008	Designed, manufactured and/or distributed under this quality management system



* Footnotes

Immersion Depth	Immersion at specified depth for 24 hours
Insertion Loss, typical	$0.05\sqrt{\text{freq (GHz)}}$ (not applicable for elliptical waveguide)